

# Repairing the drive cone of the Yanmar SD 50

Servicing a slipping clutch

## Credits, Thanks and Disclaimer:

This guide is merely a slightly amended version of the manual created by the skipper of S/V Leucat on the basis of input from Mark Scapens (S/V Isabella).

Based on their manual, I have repaired the clutch of S/Y Alytes (Lagoon 400, built November 2010) in April 2015.

I merely added some information that I found helpful and corrected some issues that seemed to be incorrect. The texts and wordings are mostly the ones of the Leucat Skipper and Mark Scapens. Accordingly, all the credit goes to these two guys.

Please be aware, that I do not know, whether Yanmar produced different variations of the SD50. The text below describes the repairs on an SD50 on a Lagoon 400 built late in 2010.

I would also like to thank the technical service of Yanmar USA. The guys there helped me tremendously to solve some issues associated with the repair. First class service on Yanmars side.

Last not least I like to thank my crew Lucas for his assistance, Greg from the Canadian Catamaran Ocenania for donating a teaspoon of lapping paste, the user michaef79 of the site mutihulls4us.com (for is excellent tip on re-securing a tricky nut) as well as "El Tigre", the one and only car mechanic on the island of Isabella, Galapagos for letting me use his workshop and vice.

In case some US-Americans are reading / using this: I will not be held liable for anything resulting - directly or indirectly - from you using this manual. If you don't agree, don't use this guide. By using it, you automatically relieve me from any liabilities. Maybe also abolish your country's liability culture in the future rendering such disclaimers obsolete ;-).

Have fun,

Fritze von Berswordt,  
S/Y Alytes, circumnavigating 2014 - 2016

## Background and Diagnosis

The Yanmar saildrive SD 50 is using a cone clutch to transmit power from the engine to the props. As stated in their operating manual, this clutch needs inspection and extended service or even replacement every 500 hours.

It is reported that the repair described herein will cost between USD 1.700 and \$ 2.500 when done by a mechanic. I can tell from my own experience, that only a mechanic familiar with the SD50 and / or with access to the official Yanmar SD 50 service and parts books will be able to perform the repair better than yourself.

The major symptom for a clutch that needs service is its failure to engage. So if your engine is running and you try to put it into forward, the lever in the cockpit moves, the engine revs up according to the throttle chosen, but the prop will not turn.

In most of the reports, this happens only in forward gear (this is handy to know, as you could still navigate your boat using reverse propulsion).

Sometimes, the clutch engages after a bit of fiddling with the remote control lever in the cockpit. This will work less and less over time.

The symptom is caused by two components that are supposed to have a rough surface but are now very smooth. The clutch needs the friction provided by the rough surfaces to establish a good connection between engine and props.

The smoothing of the involved surfaces is a result of normal operation but will occur faster if you frequently use low revs with an engaged prop (e.g. motor sailing), if you get a line in the props leading to engine stall or if you are using out of spec props (too large props). All this leads to more stress on the clutch causing it to slip and in effect causing the involved surfaces to smoothen.

So due to the issues described above, the clutch may produce problems between service intervals. In case the boat is at a location without a proper Yanmar - maintenance - specialist, skipper and crew will need to service the clutch themselves.

This guide describes how to re-establish the needed rough surface on the parts involved. This process is called lapping by the pros.

Although Yanmar offers some special tools for some of the steps described herein, the repair is absolutely possible without these rare and expensive tools.

I am a trained psychologist and working strategy consultant boasting as much mechanical know how as an albino lab rat. If I can repair a Yanmar SD 50 clutch, so can you ;-).

## Tools, Timing and Preparation

Before you start to disassemble anything on your engine check all components of the remote control devices. Especially check, whether the shifter at the clutch is actually moving at least 30° when you are engaging the engine. You should perform these checks without the engine running.

When you are sure, that your problem is not caused by issues in the cables and rods of your remote control unit, you can be pretty sure that the non-engaging clutch is caused by a slipping drive cone (and thus can be repaired as described here).

Before beginning, you should be sure that you have access to a vice. The cone drive assembly is joined very tightly. I think it can't be disassembled without a vice. The drive cone assembly is a fine piece of very partly delicate mechanics (here's the amateur speaking). Make sure, that you have a workspace that is either very clean or that you can "sanitize" using plastic bags and kitchen paper. We needed to work in a car workshop on Isabella Island, Galapagos. We needed to sanitize quite a lot to be sure that no sand, rust, grit, lapping paste or whatever remains in the assembly.

Go slow with your repairs. It is important that you organize a clean environment as well a system that allows you to reassemble the parts after repair.

As first-timers working on our 2010 Lagoon 400 it took us about three hours to remove the drive cone assembly, two hours to disassemble, roughen (lap) the surfaces and reassemble the drive cone assembly. Then another hour to return the assembly into the saildrive and clean everything up. The long removal time was caused by some errors in the original manual and the construction of the Lagoon 400's engine compartment. You could easily save about 1.5 hours in this first step.

To access, dis- and reassemble the SD50 clutch you will need the following tools (sizes are referring to European tools):

1. Wrench / Spanner Size 13 to open the housing of the drive cone assembly
2. Wrench / Spanner Size 13 to remove the shift lever assembly
3. Wrench / Spanner Size 13 to loosen bell housing nuts
4. Wrench / Spanner Size (larger than 21, unfortunately I am not 100% sure) to loosen the topmost nut of the drive cone assembly
5. Copper hammer or alternatively regular hammer to push pinion gear and shaft back
6. Nipper / Plier to pull out the clutch assembly from its housing
7. Lapping paste or alternatively fine emery paper to roughen up the critical surfaces
8. Vice with soft brackets or alternatively two aluminum pieces to protect your clutch from hard brackets to open the drive cone assembly
9. Gasoline, Diesel or similar solvent to clean all parts of the drive cone assembly after lapping
10. Oil pump, siphon tube or the like and a vessel to remove, collect and store about 200 ml of gear oil
11. A lot of kitchen paper to provide a clean working environment
12. Felt pen or permanent marker to mark some parts and positions
13. All the protective gear that you like to use or that is necessary in your country to not void your health insurance ;-)
14. Optional: 100 ml of Quicksilver gear oil to replace oil that is lost in the dis- and reassembly process (may be futile in case that you can recover and store all the oil from your clutch)
15. For Lagoon 400 (2010) owners: Wrench / Spanner Size 7 or slit screw driver to remove the exhaust pipe for accessing the SD 50 clutch assembly.

## A Quick Overview

Figure 1: Side And Top View Of Yanmar SD 40 or SD 50 Saildrive

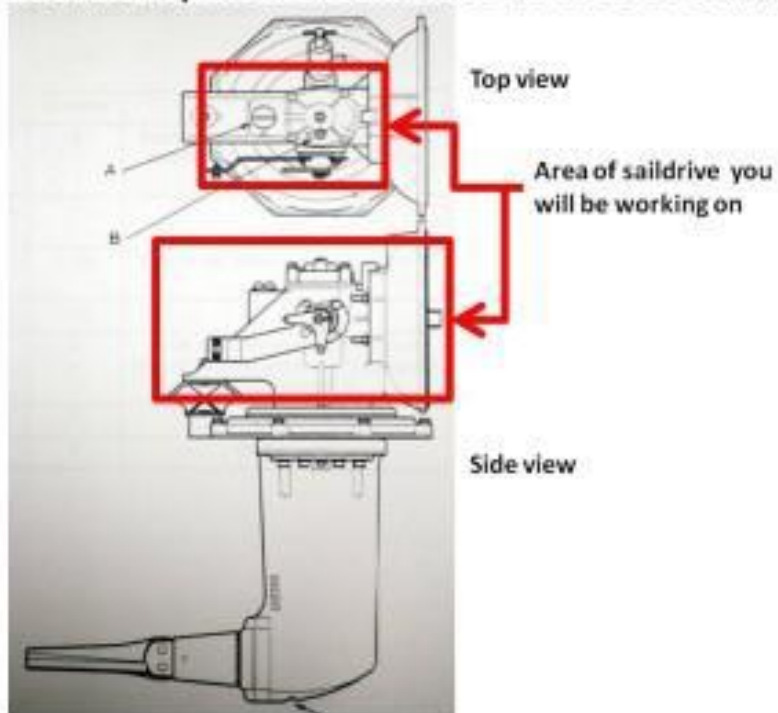

Figure 1 shows the side and top view of the saildrive and highlights the area of the saildrive you will be working on.

Figure 2: Close-up View Of What You Will Be Working On

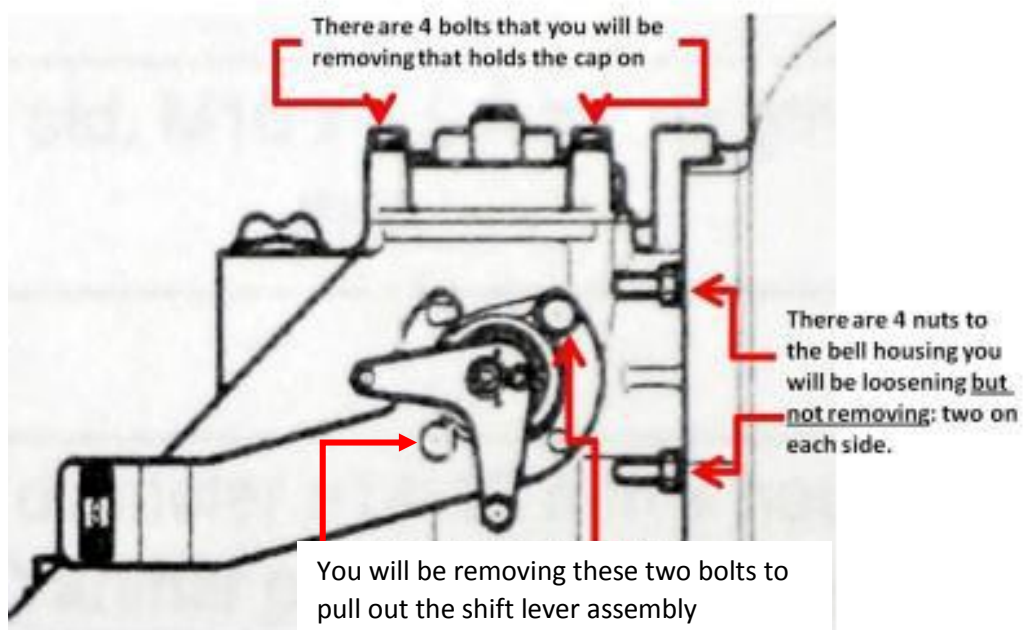

Figure 2 is a close up of the area of the saildrive you will be working on. It also shows the bolts and nuts that you will be removing or loosening.

The secret of not having to separate the engine from the saildrive and then moving the engine forward is that you will just be loosening the 4 nuts at the bell housing but not removing them from the stud bolt. You then push those stud bolts forward and it backs the pinion gear and its shaft away from the drive cone assembly and allows you to remove the drive cone assembly.

You will also be removing the shift lever assembly before you remove the drive cone assembly.

## Step 1: Drain Some Oil and Remove the Upper Cap

Figure 3: Step 1: Remove Upper Gear Tightening Bolts (4)  
And Upper Gear Cover

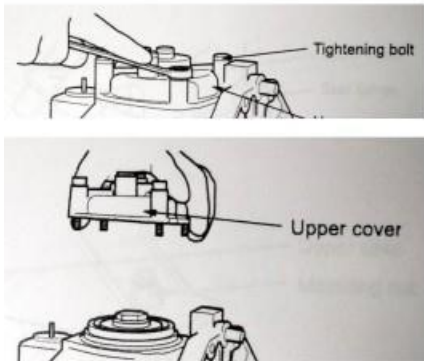

Figure 3 shows the first part of step one. Before actually opening the cap, it is recommended to pump or siphon out about 200 ml of gear oil. Some sailors did this after removing the cap, we drained oil through the dipstick opening before opening the housing. In any case, you do this so that when you remove the shift lever assembly, gear oil will not run out and get things messy.

Using a wrench, loosen and remove the four bolts that secure the upper cover cap.

Set the bolts aside and remove the cap. The picture below shows the result.



You will need one of these bolts in a later step as a impromptu tool to assist you in pulling the cone drive assembly from its housing.

Also put the cap aside. Make sure to keep it nice and clean so you don't need to clean it later.

## Step 2: Remove the Shift Lever Assembly

Now that you have the gear case's upper cover off and you have lowered the gear oil level down below the shift lever orifice, it is time to remove the shift lever assembly.

Before you start, I recommend that you set up a clean space (e.g. a plastic bag covered with kitchen paper) close to the shift lever assembly. You can then place it there while you perform the other steps without the need of cleaning it later.

Figure 4: Step 2 Remove Shift Lever Assembly

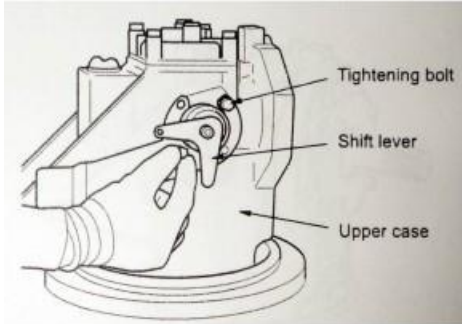

Remove the two shift lever tightening bolts

Figure 4 shows what you will be working on and Figure 5 shows what the shift lever assembly looks like.

The shift lever assembly is fixed to the gear case by two bolts:

The one labeled "Tightening bolt" and the one where the hand is in the picture (actually they are both tightening bolts for the shift lever assembly).

Use a wrench and carefully remove both bolts.

Once they are removed, carefully pull out the shift lever assembly. Be careful when you do as a spring will help push the assembly out. Make sure, that no part remains in the hole you just pulled the assembly out of.

A little T-shaped element (the shifter itself) could get stuck, you need to remove it with the rest of the assembly.

As you pull the assembly out, also make sure you note the angle the shifter is at. When you reinsert the assembly, the shifter will need to be at the same angle that it came out at.

Figure 5: Step 2 Remove Shift Lever Assembly, Con't.

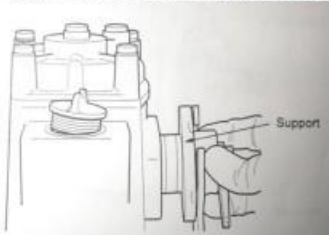

As you pull the assembly out, make sure you note the angle the shifter is at. When you reinsert the assembly, the shifter will need to be at the same angle that it came out at.

I plan on placing a mark on the side of the housing to note the position of the shifter when I pull it out. This will tell me how to position the shifter when I reassemble it.

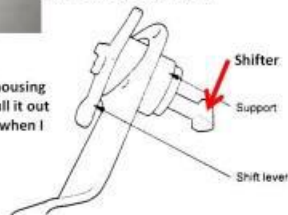

### Step 3: Loosen Bell Housing Nuts and Push Pinion Gear and Shaft Back

Now is time to do the little secret that saves you time and lots of money.

The pinion gear is what transfers the engine's torque to the saildrive and is inside the bell housing.

**Figure 6: Step 3 Loosen Bell Housing Nuts And Push Pinion Gear And Shaft Back**

This is where you need to pay attention and not do something stupid like what I would do.

The pinion gear is what transfers the engine's torque to the saildrive and is inside the bell housing

This figure has the bell housing removed and shows the pinion shaft assembly. Normally, the mechanic will separate the engine from the saildrive, back the engine off about six inches and back this pinion gear and shaft off. However, you are smarter than that! Instead, you need to only loosen the nut that is on each of the 4 stud bolts and back them off until they are just at the end of each stud bolt. **DO NOT REMOVE THE NUTS FROM THE STUD BOLTS.** Next, using a hammer, gently tap each bolt to move the pinion gear assembly back a bit so you can easily remove the drive cone assembly (see next figure).

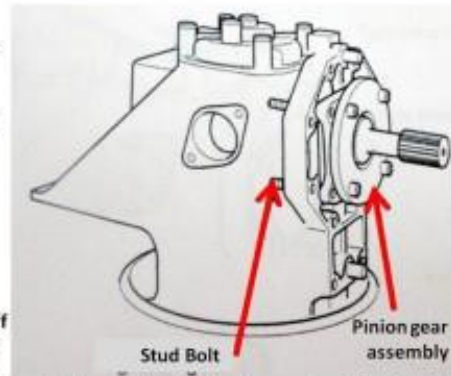

Figure 6 shows the bell housing removed and exposes the pinion shaft assembly.

You need to only loosen the nut that is on each of the 4 stud bolts and back them off until they are just at the end of each stud bolt. They should be backed in a way that the end of the bolt is slightly (really just barely) recessed in the nut. So the nut protects the bolt's threading in the next step.

Next, using a hammer, gently tap each nut/bolt to move the pinion gear assembly back a bit so you can easily remove the drive cone assembly. Do not hit the bolts with a hammer directly, as this would damage the threads.

As the pinion shaft may become stuck when you tap only on one side of the pinion gear assembly, make sure that you cycle through the four bolt/nuts when tapping them with the hammer until the nuts are touching the pinion gear housing.

## Step 4 Remove the Drive Cone Assembly

Before moving the assembly, use a felt pen to mark the assembly and the gearbox housing. This will assist lining up the assembly when re-inserting it (see step 8).

Figure 7: Step 4 Remove The Drive Cone Assembly

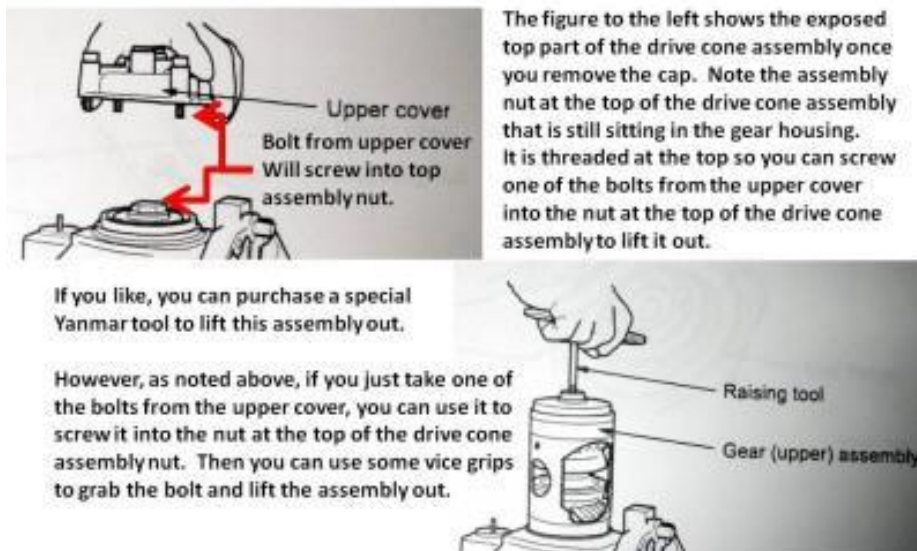

Figure 7 shows the exposed top part of the drive cone assembly once you remove the upper gear casing cover cap.

Note the nut at the top of the drive cone assembly which is still sitting in the gear housing in this picture. It is threaded at the top. If you like, you can go ahead and buy Yanmar's special extraction tool, however, if you are clever, it really is not needed. Instead, just take one of the four bolts that you removed from the upper gear casing cover cap (see Step 1). As it turns out, it has the identical threading as the drive cone assembly's top nut. Thus, all you need to do is screw in one of those bolts, grab it with a pair of vice grips or pliers and lift the drive cone assembly out.

Be patient and lift it out slowly and ideally absolutely straight. The assembly is very tightly fitted into its housing. If you tilt it too far in one direction while lifting it, it may get stuck.



Also note the rather large nut, in which the bolt mentioned above is inserted. This will be important in the next steps and is actually a tricky bit of hardware.



## Step 5 Disassembling the Drive Cone Assembly

Once you have removed the drive cone assembly (Figure 8) you need fix it in a vice with the shaft being grabbed by the vice's brackets.

**Figure 8: Step 5 Disassembling The Drive Cone Assembly**



This is what the drive cone assembly looks like once it is removed.

Once you have removed the drive cone assembly you need to insert the clutch shaft into a spline socket so you can insert the socket into a vice without damaging the splines on the shaft. I am not sure what size of spline socket you need but you can buy a universal spline socket set from Sears for under \$40. Or, you can buy Yanmar's special tool A but it is very expensive.

Once the assembly is inserted in the spline socket and you have tightened down the vice, place a wrench on the top nut (it is left handed).

You may need to place the wrench handle into a pipe to get extra leverage to remove the nut.

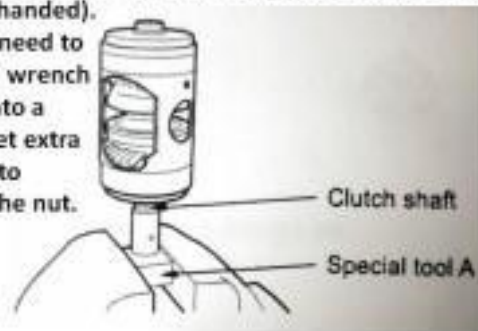

The best way would be to insert the clutch shaft into a spline socket so you can insert the socket into the vice without damaging the splines on the shaft.

I am not sure what size of spline socket you need but you can buy a universal spline socket set from Sears for under \$40. Or, you can buy Yanmar's "Special Tool A" but it is very expensive.



In the absence of the above, both Mark (S/V Isabella) and Fritze (S/V Alytes) used 2 pieces of aluminum section inserted into the vice jaws as shown in the pic....aluminum is softer than the spline...the spline wasn't damaged at all.

Once you have tightened down the vice, take a good look at the topmost nut on the assembly. You will notice, that it is secured with a fixed deform tab.

You will first have to remove the deformed part out of its associated groove in the cone drive shaft. We did it with hammer and screwdriver, others recommend a Dremel tool (we did not have that at hand in the Galapagos car workshop).

Even if you do a good job removing this safety, you may break the deform tab in part when unscrewing the nut (it is a fixed part of this topmost nut). I will describe a way how to re-secure the nut (which should be done) later in step seven.

Once the assembly is fixed in the vice and the safety is removed, place a wrench on the top nut (it is left handed, so it opens turning clockwise).

You may need to place the wrench handle into a pipe

to get extra leverage to remove the nut.

With the nut off, you can slip off the spacer and disassemble the assembly (see Figure 9).

**Figure 9: Step 5 Disassembling The Drive Cone Assembly, Con't.**

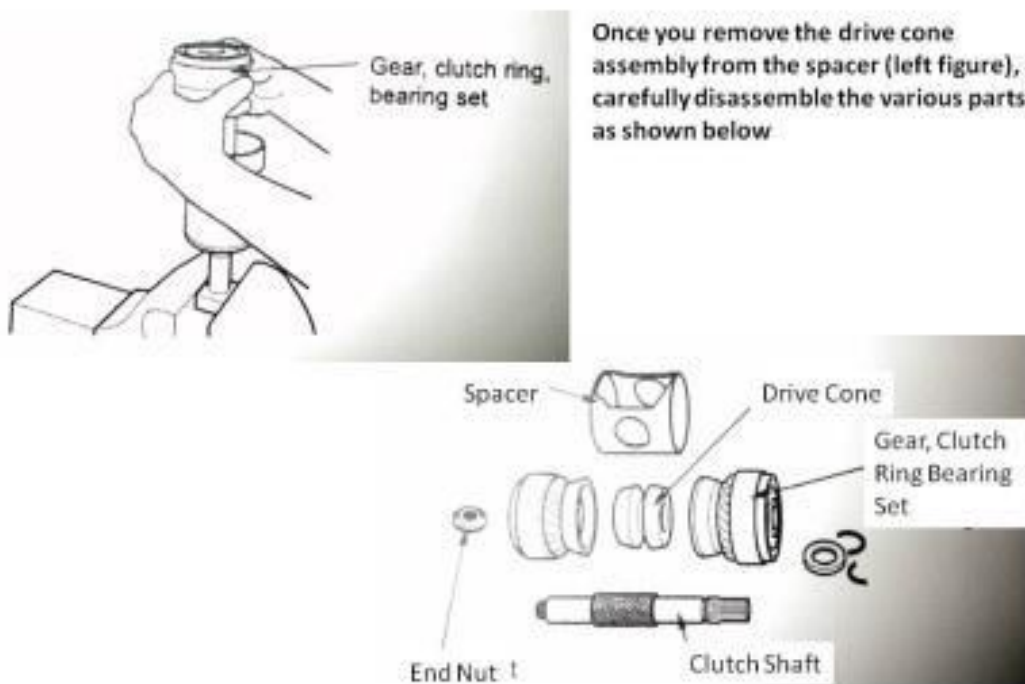

NOW ITS TIME TO GO SLOW!!! Make sure you use a system to layout the parts in some sort of order. We used a scribing tool to mark the "top" of the 3 gears and cone.

### Step 6 Inspecting the Drive Cone And Gear

Once you have disassembled the drive cone assembly, inspect the upper side and lower side gears where they make contact with the drive cone to check if any abnormal condition or signs of overheating exists (see area 1 in the upper left hand picture in Figure 10).

**Figure 10: Step 6 Inspecting The Drive Cone And Gear**

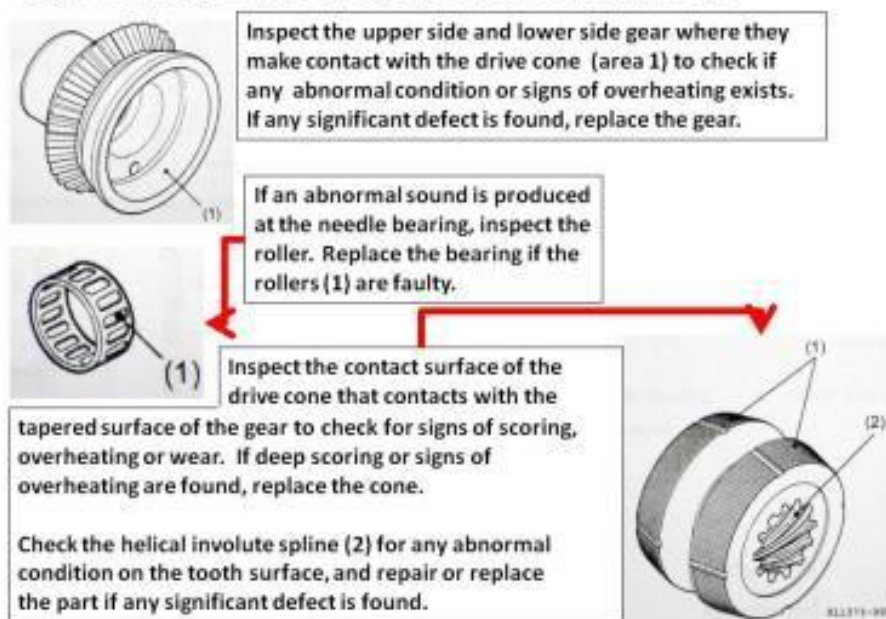

If any significant defect is found, you should consider replacing the gear. Inspect the roller (see the middle picture in Figure 10) and if an abnormal sound is produced at the needle bearing this means the rolls are faulty and the bearing needs to be replaced.

Inspect the surface of the drive cone that contacts with the tapered surface of the gear to check for signs of scoring, overheating or wear (see the bottom right picture in Figure 10).

You will most likely find both the cone and the gears (Area 1 in Figure 10) smooth and glazed. That is your problem, its removal will be addressed in Step 7. But while you're at it, inspect some more:

If deep scoring or signs of overheating are found, replace the cone. Oil is "squeezed" into the horizontal grooves on the cone when it's engaged. If the ridges have been worn flat, then the cone will definitely need replacement.

Check the helical involute spline (2) for any abnormal condition on the tooth surface, and repair or replace the part if any significant defect is found (see the bottom right picture in Figure 10).

## Step 8 Lapping the Drive Cone (reestablishing the rough surfaces)

Figure 11 demonstrates how the rough surfaces in the drive cone assembly are reestablished. In the figure, lapping pasted (#280) is used for that.

**Figure 11: Step 7 Lapping Procedure For Drive Cone**

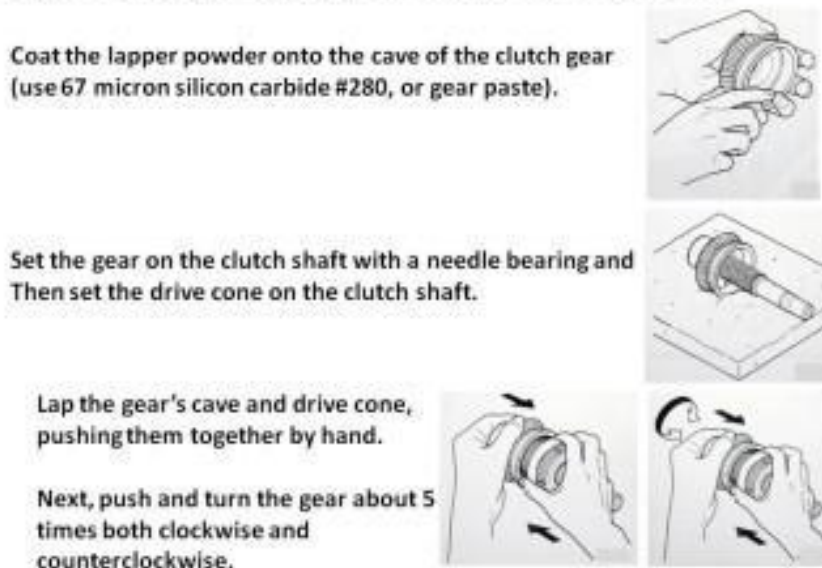

Definitely, lapping paste is the best way to do it.

But this paste is usually not part of your tools and materials list. If you are in a remote place (as we were in Galapagos), it may be hard or impossible to find.

Alternatively some sailors have used emery paper (280 grains or finer) to cautiously roughen up the surfaces of the cones and the gears.

The issue is, that the tolerances within the assembly are quite small. But it is reported that emery paper can be used if applied very, very cautiously. I would not recommend it, but in case of emergency I would also use fine emery paper.

**Figure 12: Step 7 Lapping Procedure For Drive Cone, Cont.**

After lapping them, wash them with kerosene or similar solvent. They need to be washed thoroughly so no grit is present.



When assembling the drive cone, be sure to check its alignment. The larger diameter 044 face should be on the lower gear side.

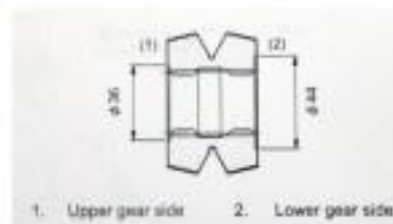

When you are finished, make sure that you clean every part of the assembly thoroughly with kerosene, gasoline or a similar solvent. It is of high importance to get all the grit and residue from the lapping out of the assembly.

Also make sure, that you re-insert the cone the right way (Figure 12).

## Step 8 Reassembling the Drive Cone

You are now ready to put everything back together again. To do this, look at Figure 5 and reassemble the drive cone assembly.

Once assembled, reinsert it back into the drive cone spacer. Place the spline socket back onto the shaft and put the entire unit back into the vice and tighten the vice.

Now it is time to tighten and secure the top nut. I guess Yanmar will use a new nut every time the nut was removed, as the deform tab to secure it will most likely broken. Normally, you probably do not have such a replacement at hand, so you need to re-secure the one you most likely rendered unusable when you undid the top nut.

One way to secure it, would be to use some Loctite (red) along the threads.

We preferred a more secure method. For that we chose to cut a new groove into the shaft of the drive cone assembly with a brand new angle grinder disk (tip to the head to [michaef79](https://www.multihulls4us.com) for his good post on [multihulls4us.com](https://www.multihulls4us.com)). We had only about a third of the deform tap on the top nut, so we cut the groove exactly at the point, where this remainder could be used to re-secure the nut to the shaft.

Now you can reinsert the drive cone assembly back into the gear housing. After all this cleaning with kerosene and solvents, it is most likely very dry. It is therefore helpful to cover the outside of the assembly with copious amounts of gear lube (simply use your Quicksilver lube). Insert the assembly absolutely straight, as it may jam in the very tight fitting housing, otherwise.

Tighten the four nuts on the stud bolts that are still in the bell housing to bring back the pinion gear assembly back into place. Again, there is a risk of jamming, if you simply tighten the nuts on one side and then the other. Reports of damaged clutches due to jammed pinion shafts have been made by at least one sailor.

To prevent this, tighten the first nut only for a couple of turns. Then tighten the one on the opposite side of the bell housing. Then start with the second "pair" of nuts and continue to cycle through opposite nut pairs and thus slowly and straightly drive the pinion shaft back into the drive cone assembly.

Reinsert the shift lever assembly making sure the shifter is at the same position that it was when you removed it. This is where your mark on the housing can help. Tighten the two tightening nuts.

Replace the gear cover and tighten the four bolts and replace the gear oil that you drained.

Caution: most likely, not all of the oil you drained can be refilled in the first run as the very viscose oil needs some time to seep into all the little crevices and holes. We filled it to the top (leaving some oil in reserve), started the engine and engaged for 1 minute. Then poured the rest. Actually we had to add some more oil (about 50 ml) as we lost some of it during the siphoning and disassembly.

Open a beer, take a big swig and then start up the engine and put to engine into gear and pray! If all went well, your prop is spinning in gear and you are under way. If not, oh well, you are no worse off than before and you only spent a few hours of time. You can always call the mechanic and get out the loan application to pay for the big dollars he will be charging you!